



I.R.E.P S.A.S
59450 Sin le Noble - France
Tel.: +33 (0) 27 93 08 08
Fax: +33 (0) 27 93 08 00

Copyright © 2008.Ingersoll-Rand Company
All Rights reserved.

LIFTCHAIN LC2A Series Model LC2A080D...-E

Hook Mount 8 Ton Lifting capacity



IREP Drawing Number	Rev.
08/04/13-L645	
Customer Drawing Number	
Folio :	1/1
Engineering Mgr. Approval : JLF	

Standard Features :

- Rugged and Compact modular design
- Design temperature -20°C
- Explosion proof - 100% duty rating - No downtime
- Gear type air motor with high starting torque providing long life
- Variable speed control at pilot pendant or pull chain
- Overload protection device adjusted at factory during load tests
- Main air emergency stop at pendant as per EN 418
- Top and bottom limit switches intergrated in hoist body for better protection
- Automatic fail safe disc brake (no adjustment required)
- Zinc plated load chain for corrosion resistance
- Exhaust muffler for quiet operation
- Sound pressure level < 84 dBA
- Suitable for horizontal pulling applications
- Low maintenance cost
- Individually load tested before shipment

*It is strongly recommended to use a lubricating and a filtration system on the compressed air line.
The compressed air temperature must not exceed 65°C at the motor air inlet.
For higher temperature, please consult us.*

Options:

- Spark resistant package for ATEX zone 1
- Chain containers
- Marine or offshore paint including sandblasting
- Trolley mount versions (plain, geared or motorized)
- Mining versions and hydraulic versions available

Ex classifications (ATEX)

- Standard version is suitable for Zone 2 (ATEX Marking Ex II 3 GD c IIB 135°C x)
- Optional spark resistant package is suitable for Zone 1 (ATEX marking Ex II 2 GDc IIB135°Cx)

FEM classification

- Driving mechanism classification 1Bm

Built in ISO 9001 certified factory

Technical data at 6.3 bar

Model	LC2A080D-E
Rated Capacity (metricTon)	8
Falls of chain	2
Lifting speed at rated load (m/min)	1.8
Lifting speed at no load (m/min)	3.5
Lowering speed at rated load (m/min)	2.2
Working pressure range (Bar)	4 to 7
Air consumption at rated load (m ³ /min)	4.4
Minimum headroom (mm)	807
Air inlet (BSP)	3/4
Chain size (mm)	13x36
*Weight with std lift (Kg)	118
Chain Weight per meter of lift (kg)	7.6

*Net weight is given with standard lift of 3m and standard control length of 2m

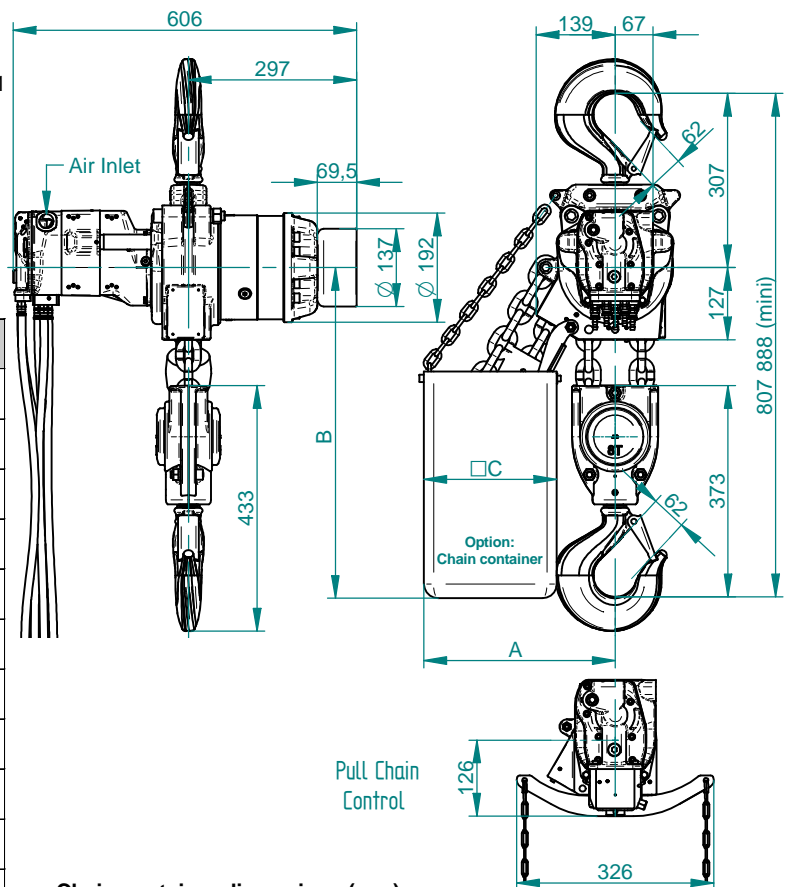
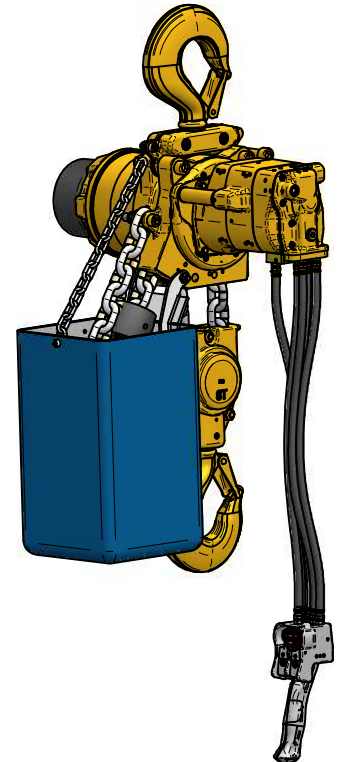

Chain container dimensions (mm)

Height of lift	A	B	C	Option code
6 m	338	583	230	A
12.5 m	418	683	315	B
20 m	418	843	310	C