



I.R.E.P S.A.S  
59450 Sin le Noble - France  
Tel.: +33 (0) 27 93 08 08  
Fax: +33 (0) 27 93 08 00

Copyright © 2008. Ingersoll Rand Company  
All Rights reserved.

# LIFTCHAIN LC2A Series Model LC2A180T...-E Hook Mount 18 ton Lifting capacity



IREP Drawing Number	Rev.
08/04/19-L645	B
Customer Drawing Number	
Folio :	1/1
Engineering Mgr. Approval : JLF	

### Standard Features :

- Rugged and Compact modular design
- Design temperature -20°C
- Explosion proof - 100% duty rating - No downtime
- Gear type air motor with high starting torque providing long life
- Variable speed control at pilot pendant or pull chain
- Overload protection device adjusted at factory during load tests
- Main air emergency stop at pendant as per EN 418
- Top and bottom limit switches intergrated in hoist body for better protection
- Automatic fail safe disc brake (no adjustment required)
- Zinc plated load chain for corrosion resistance
- Exhaust muffler for quiet operation
- Sound pressure level = 79 dBA
- Suitable for horizontal pulling applications
- Easy maintenance
- Individually load tested before shipment

*It is strongly recommended to use a lubricating and a filtration system on the compressed air line.  
The compressed air temperature must not exceed 65°C at the motor air inlet.  
For higher temperature, please consult us.*

### Options:

- Spark resistant package for ATEX zone 1
- Chain containers
- Marine or offshore paint including sandblasting
- Trolley mount versions (plain, geared or motorized)
- Mining versions and hydraulic versions available

### Ex classifications (ATEX)

- Standard version is suitable for Zone 2 (ATEX Marking Ex II 3 GD c IIB 135°C x)
- Optional spark resistant package is suitable for Zone 1 (ATEX marking Ex II 2 GDc IIB135°Cx)

### FEM classification

- Driving mechanism classification 1Bm

### Built in ISO 9001 certified factory

### Technical data at 6.3 bar

Model	LC2A180T-E
Rated Capacity (metric ton)	18
Falls of chain	3
Lifting speed at rated load (m/min)	0.7
Lifting speed at no load (m/min)	1.2
Lowering speed at rated load (m/min)	0.9
Working pressure range (bar)	4 to 7
Air consumption at rated load (m <sup>3</sup> /min)	5
Minimum headroom (mm)	1063
Air inlet (BSP)	3/4
Chain size (mm)	16x45
*Weight with std lift (kg)	277
Chain Weight per meter of lift (kg)	17.1

*\*Net weight is given with standard lift of 3m and standard control length of 2m*

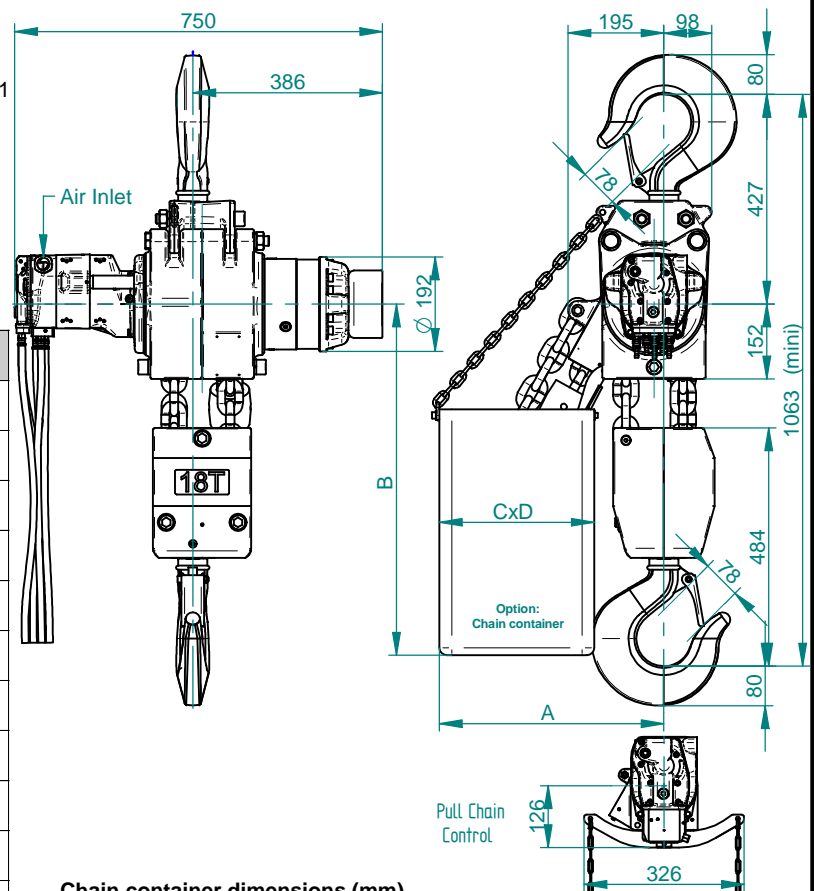
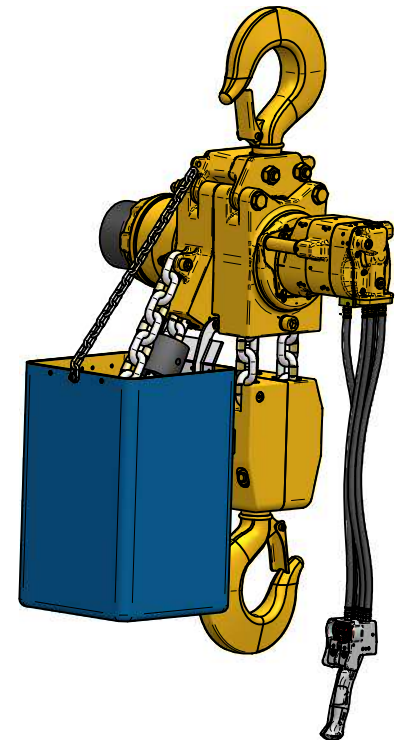

### Chain container dimensions (mm)

Height of lift	A	B	CxD	Option code
4m	457	715	315x315	A
8.5 m	547	915	400x400	B
13 m	547	915	550x400	C